

REV	DESCRIPTION	DATE
A	CORRECTED RACK MOUNT BRACKET DETAIL	10/16/01

NOTES

MATERIAL TOP & BOTTOM 0.062" STEEL, SIDES, FRONT, REAR & HORIZONTAL SUPPORTS 0.125" ALUMINUM, DIMENSIONS ARE TAKEN WITH THE PAINTED SURFACE

FINISH TOP, BOTTOM & SIDE PANELS, TEXTURED BLACK, FRONT/REAR PANELS ON SMOOTH BLACK, ONE CONTEMPRA GRAY (RAL 7032), ALL POWDER PAINT,

FRONT VIEW

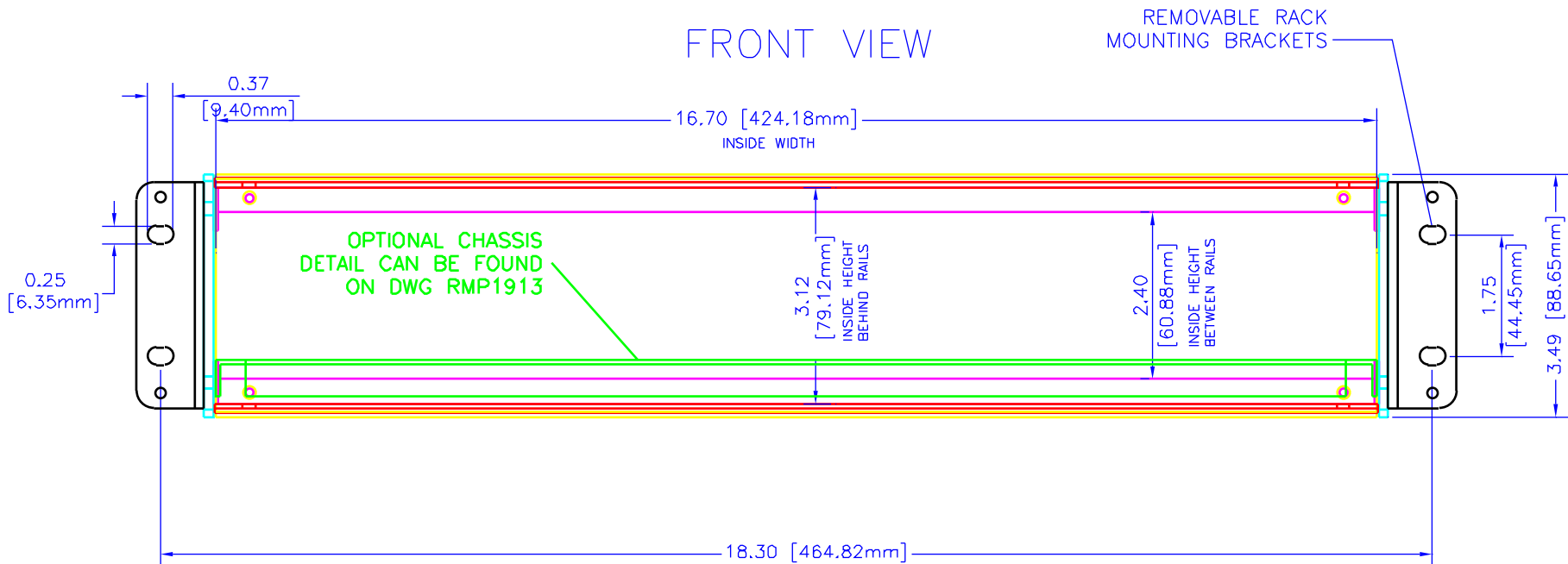

UNLESS OTHERWISE SPECIFIED
DIMENSIONS ARE IN INCHES

X +/- .1
XX +/- .02
XXX +/- .015
CUTS +/- .005
ANGLES +/- 5 DEC.



**HAMMOND
MANUFACTURING**

WEB: WWW.HAMMONDMFG.COM

TITLE **HAMMOND RMCS SERIES
RACK ENCLOSURE**

DRAWN BY **MJM** DATE **10/04/01**

SCALE PAGE **1 OF 3**

PART NUMBER

RMCS190313

SIDE VIEW

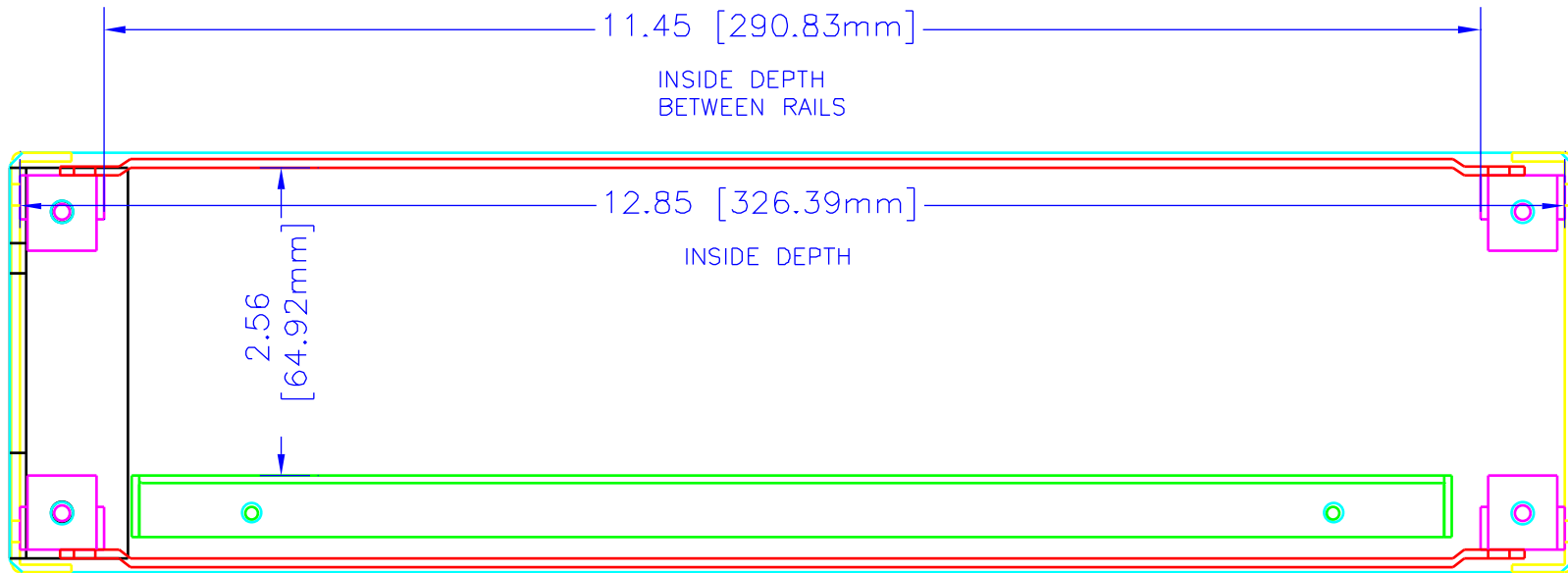

UNLESS OTHERWISE SPECIFIED
DIMENSIONS ARE IN INCHES

X	+/- .1
XX	+/- .02
XXX	+/- .015
FUITS	+/- .000
ANGLES	+/- .5 DEG.

NOTES:
HAMMOND RESERVES PROPRIETARY RIGHTS TO
THE MATERIAL ON THIS DRAWING. IT IS
INTENDED TO BE USED AS A REFERENCE FOR
ENGINEERING INFORMATION ONLY. THIS
INFORMATION MAY NOT BE USED TO
MANUFACTURE PRODUCTS WITHOUT WRITTEN
PERMISSION FROM HAMMOND MANUFACTURING



**HAMMOND
MANUFACTURING**

WEB: WWW.HAMMONDMFG.COM

TITLE		HAMMOND RMCS SERIES RACK ENCLOSURE	
DRAWN BY	MJM	DATE	10/04/01
SCALE		PAGE	2 OF 3
PART NUMBER		RMCS190313	

TOP VIEW

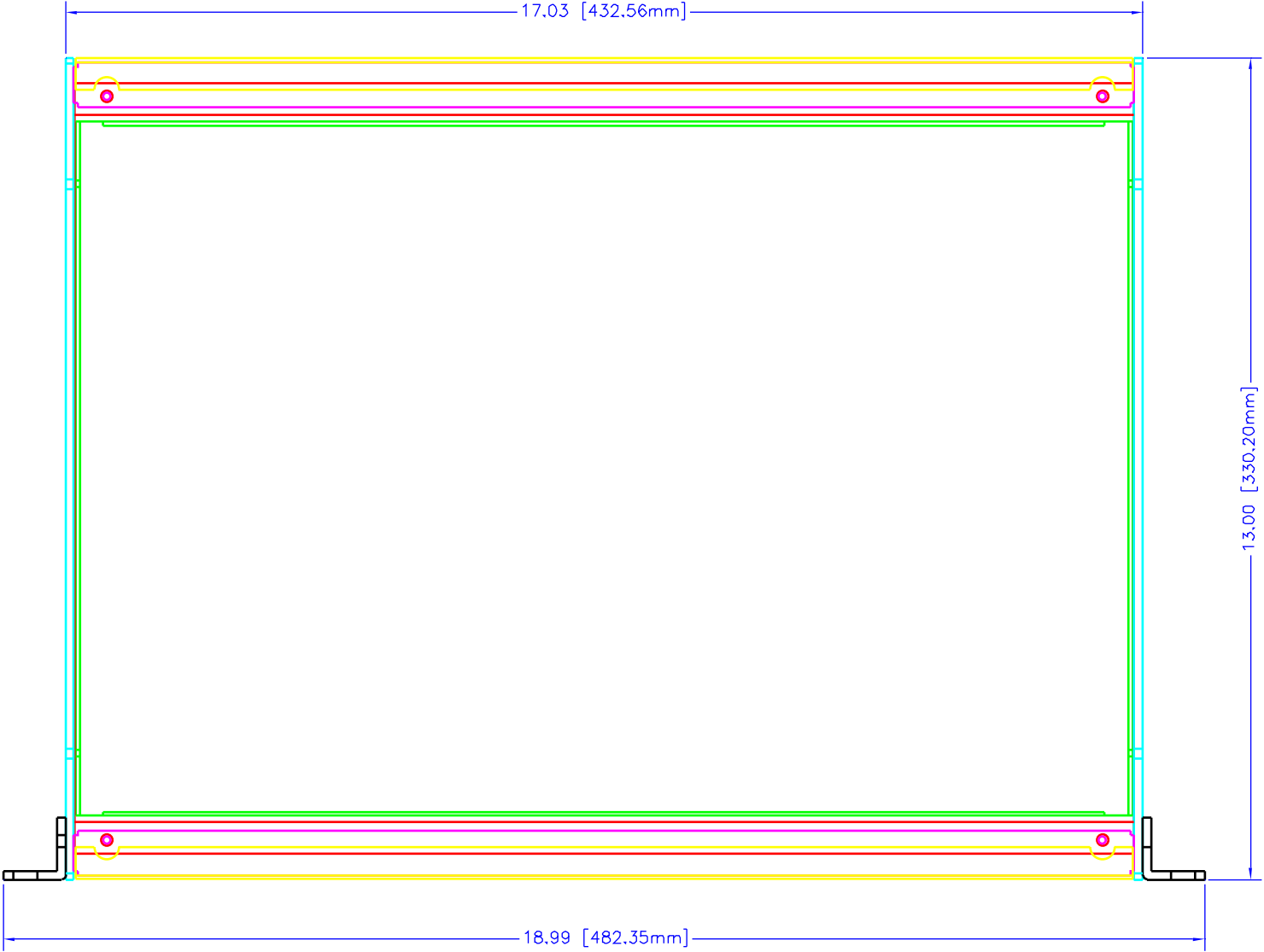

UNLESS OTHERWISE SPECIFIED
DIMENSIONS ARE IN INCHES

X	+/- .1
XX	+/- .02
XXX	+/- .015
FITS	+/- .000
ANGLES	+/- .5 DEG.

NOTES:
HAMMOND MANUFACTURING RESERVES ALL RIGHTS TO THE MATERIAL ON THIS DRAWING. IT IS INTENDED TO BE USED AS A REFERENCE FOR ENGINEERING INFORMATION ONLY. THIS INFORMATION MAY NOT BE USED TO MANUFACTURE PRODUCTS WITHOUT WRITTEN PERMISSION FROM HAMMOND MANUFACTURING.



**HAMMOND
MANUFACTURING**

WEB: WWW.HAMMONDMFG.COM

TITLE		HAMMOND RMCS SERIES RACK ENCLOSURE	
DRAWN BY	MJM	DATE	10/04/01
SCALE		PAGE	3 OF 3
PART NUMBER		RMCS190313	